

DOP Efficiency @ .3 micron	95% DOP		99.97% DOP		99.99% DOP	
Gasket/Gel	Neoprene	Gel Seal	Neoprene	Gel Seal	Neoprene	Gel Seal
EUROVENT Classification	EU 10		EU 12		EU 13	
Part # (24 x 24)	40421	Contact Factory	40418	41897	40419	73892
Rated Air Flow (cfm)	2400	2100	2400	2100	2400	2100
Media Surface Area (sq. ft.)	430	400	430	400	430	400
Rated Initial Pressure Drop ("w.g.)	0.86	0.86	1	1	1	1
Recommended Final Pressure Drop ("w.g.)	2.4	2.4	2.4	2.4	2.4	2.4
Maximum Final Pressure Drop ("w.g.)	3	3	3	3	3	3
Maximum Continuous Temperature (°F)	250	150	250	150	250	150
Half-Sizes	40424	Contact Factory	40425	Contact Factory	40426	Contact Factory
Rated Air Flow (cfm)	1200		1100		1100	
Media Surface Area (sq. ft.)	215		215		215	
Rated Initial Pressure Drop ("w.g.)	0.86		1		1	
Recommended Final Pressure Drop ("w.g.)	2.4		2.4		2.4	

For Sales Only

Customer Information: \_\_\_\_\_

Item Number: \_\_\_\_\_

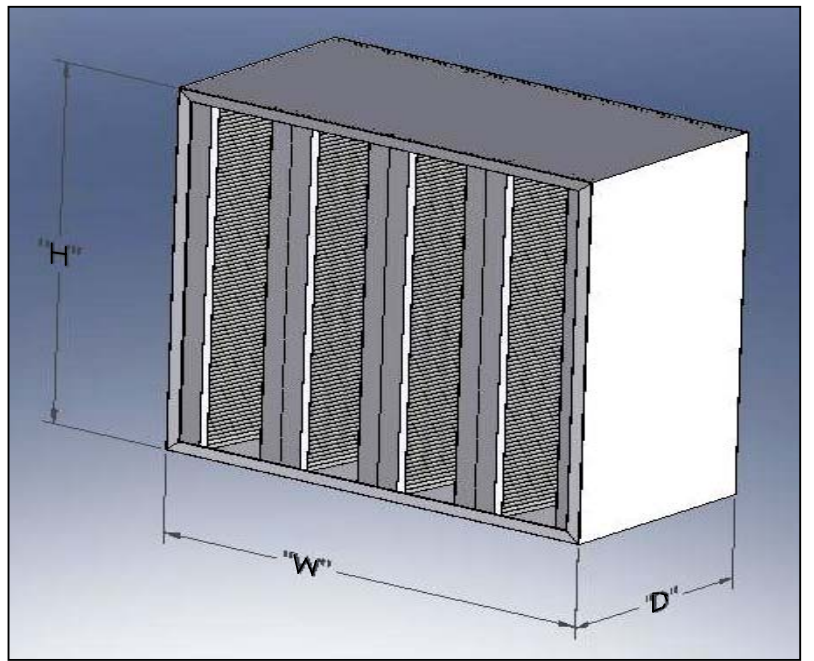

Characteristics	Aerostar HIGH VOLUME HEPA
Media	Wet laid micro glass
Frames	Extruded Aluminum Frame
Gasket	Gel Seal or Closed Cell Poron, Upstream Side
Separators	Continuous Strand Thread
Pack Adhesive	Polyurethane
UL	UL 900 - Class 2
Actual Filter Dimensions	Made to exact dimensions, please consult customers service

For Non-Standard Sizes, Please Consult the Factory.

\_\_\_\_\_ (H) X \_\_\_\_\_ (W) X 11-1/2" (D)

Please Specify Size as Nominal or Exact \_\_\_\_\_

Customer Initial and Date for Non-Standard Size \_\_\_\_\_

**Filtration Group, Inc.**  
**912 East Washington Street**  
**Joliet, Illinois 60433**

**HEPA Filters**

YOUR APPROVAL OF THIS PRINT AUTHORIZES FILTRATION GROUP, INC. TO PROCEED WITH MATERIAL PROCUREMENT, TOOLING AND PRODUCT FABRICATION. ANY CHANGES MADE AFTER APPROVAL MAY INCUR FURTHER EXPENSES TO THE CUSTOMER.

Extruded Aluminum Frame					
DR:	ARZ	Date:	12/11/2003	Drawing Number:	Revision:
CK:	RC	Date:		<b>SD-HVEX-HEPA</b>	<b>D</b>