

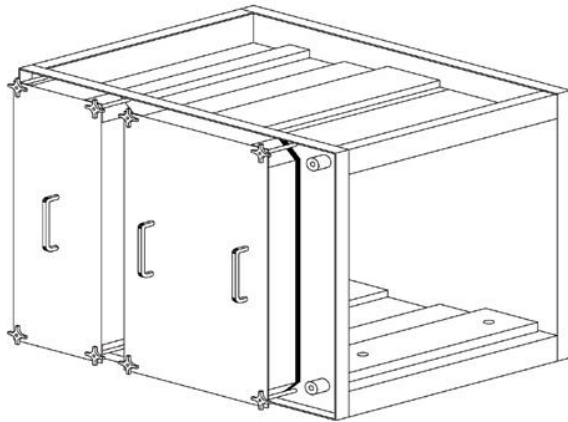

HEPA SEAL BAG IN/BAG OUT QUOTE/SUBMITTAL

Date _____ Customer: _____ Quote No. _____



Gasket Seal Fluid Seal

Door Location Right Hand (standard) Left Hand

Material
 Aluminized Steel 14 GA
 304L Stainless Steel 14 GA
 316L Stainless Steel 14 GA

<u>Size</u> (check height and width box)	<u>Height</u>	<u>Dimension</u>	<u>Width</u>	<u>Dimension</u>
	<input type="checkbox"/> 1 H	29 3/4"	<input type="checkbox"/> 1 W	27"
	<input type="checkbox"/> 2 H	59 1/2"	<input type="checkbox"/> 2 W	51"
	<input type="checkbox"/> 3 H	89 1/2"	<input type="checkbox"/> 3 W	75"
	<input type="checkbox"/> 4 H	119"		
<u>Other Size</u>	N/A	N/A	N/A	N/A

Depth
 24" -No Pre-Filter
 36 1/2" 2" Pre-Filter
 36 1/2" 4" Pre-Filter
 36 1/2" 6" Pre-Filter

Special Size Height _____ Width _____ Depth _____

- Options**
- | | |
|---|---|
| <input type="checkbox"/> Bag Kit HEPA Gasket Seal | <input type="checkbox"/> Double Wall Insulation |
| <input type="checkbox"/> Bag Kit HEPA Fluid Seal | <input type="checkbox"/> Insulation |
| <input type="checkbox"/> Bag Kit Pre Filter | <input type="checkbox"/> Bottom Access |
| <input type="checkbox"/> Nameplate (engraved) | <input type="checkbox"/> Filter Support Shelf |
| <input type="checkbox"/> Vertical Flow | <input type="checkbox"/> Weather Cover |
| <input type="checkbox"/> Drain | <input type="checkbox"/> Transitions |
| <input type="checkbox"/> Drilled Flanges | <input type="checkbox"/> 2 Static Taps |
| <input type="checkbox"/> 2 Lifting Lugs | <input type="checkbox"/> 4 Static Taps |
| <input type="checkbox"/> 4 Lifting Lugs | <input type="checkbox"/> High Temperature Door Gasket |
| <input type="checkbox"/> Silicone Door Gasket | <input type="checkbox"/> Magnehelic Gauge |
| <input type="checkbox"/> Magnehelic Gauge | Model # _____ Uninstalled |
| Model # _____ Installed | <input type="checkbox"/> Photohelic Gauge |
| <input type="checkbox"/> Photohelic Gauge | Model # _____ Uninstalled |
| Model # _____ Installed | <input type="checkbox"/> NEMA4 Cover |
| <input type="checkbox"/> 1 DOP Port | <input type="checkbox"/> Weld Sections in Series |
| <input type="checkbox"/> 2 DOP Ports | <input type="checkbox"/> Absorber Section (16 or 18") |
| <input type="checkbox"/> Bolt Sections in Series | <input type="checkbox"/> Spare Door |
| | <input type="checkbox"/> Pre-Filter Section Only |
| <input type="checkbox"/> Other _____ | |