

EFF.	Part Number	Nominal Size HxWxD	Media Area (ft <sup>2</sup> )	Number of Pleats	Rated Air Flow			Initial Resistance		
					Low	Med	High	Low	Med	High
90-95%	16403	24x24x12	52	15	1000	1500	2000	.29	.43	.71
	16400	24x12x12	24	7	500	750	1000	.29	.43	.71
	16401	20x20x12	34	12	700	1050	1400	.29	.43	.71
80-85%	16411	24x24x12	52	15	1000	1500	2000	.22	.31	.53
	16408	24x12x12	24	7	500	750	1000	.22	.31	.53
	16409	20x20x12	34	12	700	1050	1400	.22	.31	.53
60-65%	16419	24x24x12	52	15	1000	1500	2000	.17	.30	.45
	16416	24x12x12	24	7	500	750	1000	.17	.30	.45
	16417	20x20x12	34	12	700	1050	1400	.17	.30	.45
40-45%	16427	24x24x12	52	15	1000	1500	2000	.24	.29	.32
	16424	24x12x12	24	7	500	750	1000	.24	.29	.32
	16425	20x20x12	34	12	700	1050	1400	.24	.29	.32

Characteristics	Aerostar Rigid Cell Header Style Filter
Laminated Media	High Lofted Ultra Fine Fiberglass Media thick expanded metal backing.
Pleat Separators	Fire Retardant High Impact Polystyrene, 4 upstream and 4 downstream Also Available in Galvanized Steel. Please consult factory for Steel Separators.
Cross Braces	Galvanized Steel, 4 upstream and 4 downstream, attached to frame.
Header	24 Gauge MSB Galvanized Steel, one piece wrap-around design, upstream. Double header style available, please consult factory for available sizes.
Frame	26 Gauge Galvanized Steel, two piece design.
ASHRAE Efficiency	Efficiency is average and is based on ASHRAE Standard 52.1 dust spot testing methods.
Max. Temperature	180 °F (82 °C).
Max. Humidity	100% Relative Humidity.
Flammability (UL File R12347)	UL900 Class 2 US and Canada. UL900 Class 1 US Only (Available only with polystyrene separators listed above).
Gasket	Upstream, Downstream, and Side Gaskets available. Please consult factory.
Height Tolerance	+0 and -1/8"
Width Tolerance	+0 and -1/8"
Depth Tolerance	± 1/16"
Actual Frame Size	Height and width less 5/8" of nominal size and 12" depth=11-3/8" and 6" depth=5-3/4".

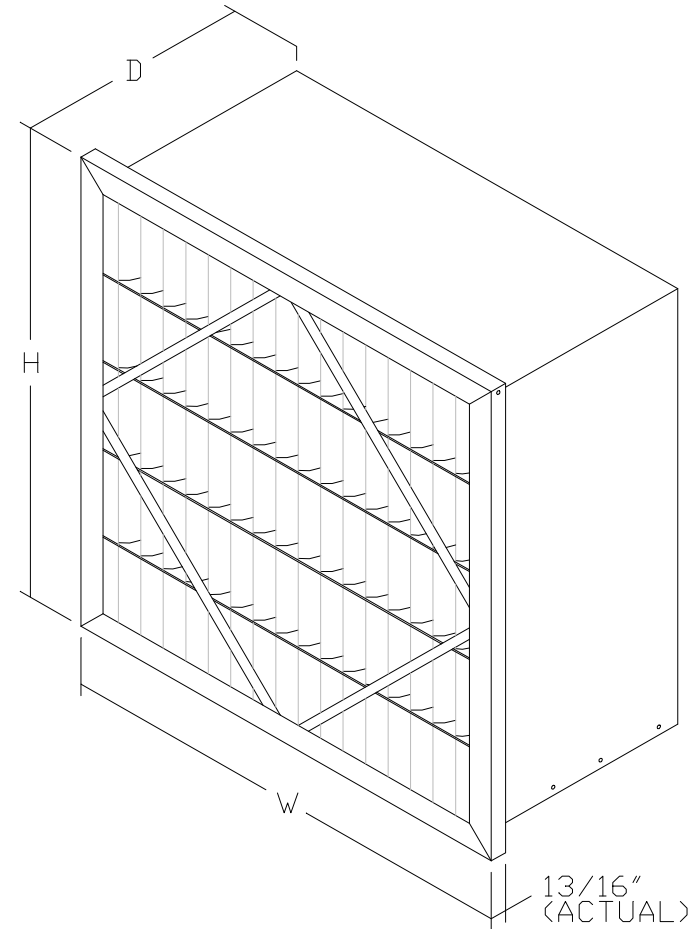

For Non-Standard Sizes, Please Consult the Factory.  
 \_\_\_\_\_ (A) X \_\_\_\_\_ (H) X \_\_\_\_\_ (D)  
 Please Specify Size as Nominal or Exact \_\_\_\_\_  
 Customer Initial and Date for Non-Standard Size \_\_\_\_\_

 **Filtration Group, Inc.**  
**913 East Washington Street**  
**Joliet, Illinois 60433**

**Aerostar**  
**Fiberglass Rigid Cell - Header Style**

DR:	JMB	Date:	12/10/2004	Drawing Number:	<b>SD-RC-HDR-FG</b>	Revision:	<b>C</b>
CK:		Date:					

YOUR APPROVAL OF THIS PRINT AUTHORIZES FILTRATION GROUP, INC. TO PROCEED WITH MATERIAL PROCUREMENT, TOOLING AND PRODUCT FABRICATION. ANY CHANGES MADE AFTER APPROVAL MAY INCUR FURTHER EXPENSES TO THE CUSTOMER.