

For Sales Only

Customer Information: \_\_\_\_\_

Item Number: \_\_\_\_\_

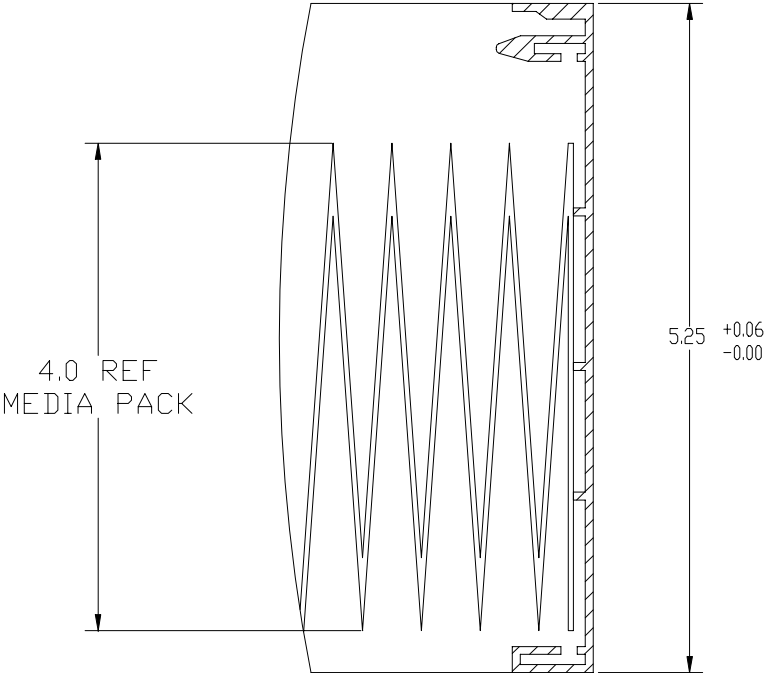

Available Options	Check If Desired
Downstream Screen in Anodized Aluminum	<input type="checkbox"/>
Downstream Screen in Stainless Steel	<input type="checkbox"/>
Upstream Gasket	<input type="checkbox"/>
Downstream Gasket	<input type="checkbox"/>
Both, Upstream and Downstream Gaskets	<input type="checkbox"/>
Specify HEPA or ULPA	<input type="checkbox"/>

Characteristics	Cleanroom Filter CP-19
Filter Media	Micro-Glass Fiber.
Pleat Separator	Continuous String or Hot Melt Glue.
Frame Material	Extruded Aluminum.
Sealant Material	Polyurethane.
Downstream Screen	White Powdered Coated.
Pleat Depth	4".
Efficiency HEPA	99.99% min. on 0.3 micron particulate at rated flow.
Efficiency ULPA	99.9995% min. on 0.1 - 0.2 micron particulate at rated flow
Nominal Size	(Size) - (3/8")

SECTION A-A

For Non-Standard Sizes, Please Consult the Factory.

\_\_\_\_\_ (A) X \_\_\_\_\_ (B) X \_\_\_\_\_ 5.25"

Please Specify Size as Nominal or Exact \_\_\_\_\_

Customer Initial and Date for Non-Standard Size \_\_\_\_\_

 **Filtration Group, Inc.**  
**971A Industrial Dr.**  
**Aurora, IL 60506**

**Cleanroom Filter**  
**CP-19**

YOUR APPROVAL OF THIS PRINT AUTHORIZES FILTRATION GROUP, INC. TO PROCEED WITH MATERIAL PROCUREMENT, TOOLING AND PRODUCT FABRICATION. ANY CHANGES MADE AFTER APPROVAL MAY INCUR FURTHER EXPENSES TO THE CUSTOMER.

DR:	ARZ	Date:	11/12/2003	Drawing Number:	<b>SD-CP-19</b>	Revision:	<b>00</b>
CK:		Date:					